

DUCKBILL®

Ground Anchor Systems

**PRODUCT RANGE and
TECHNICAL INFORMATION**

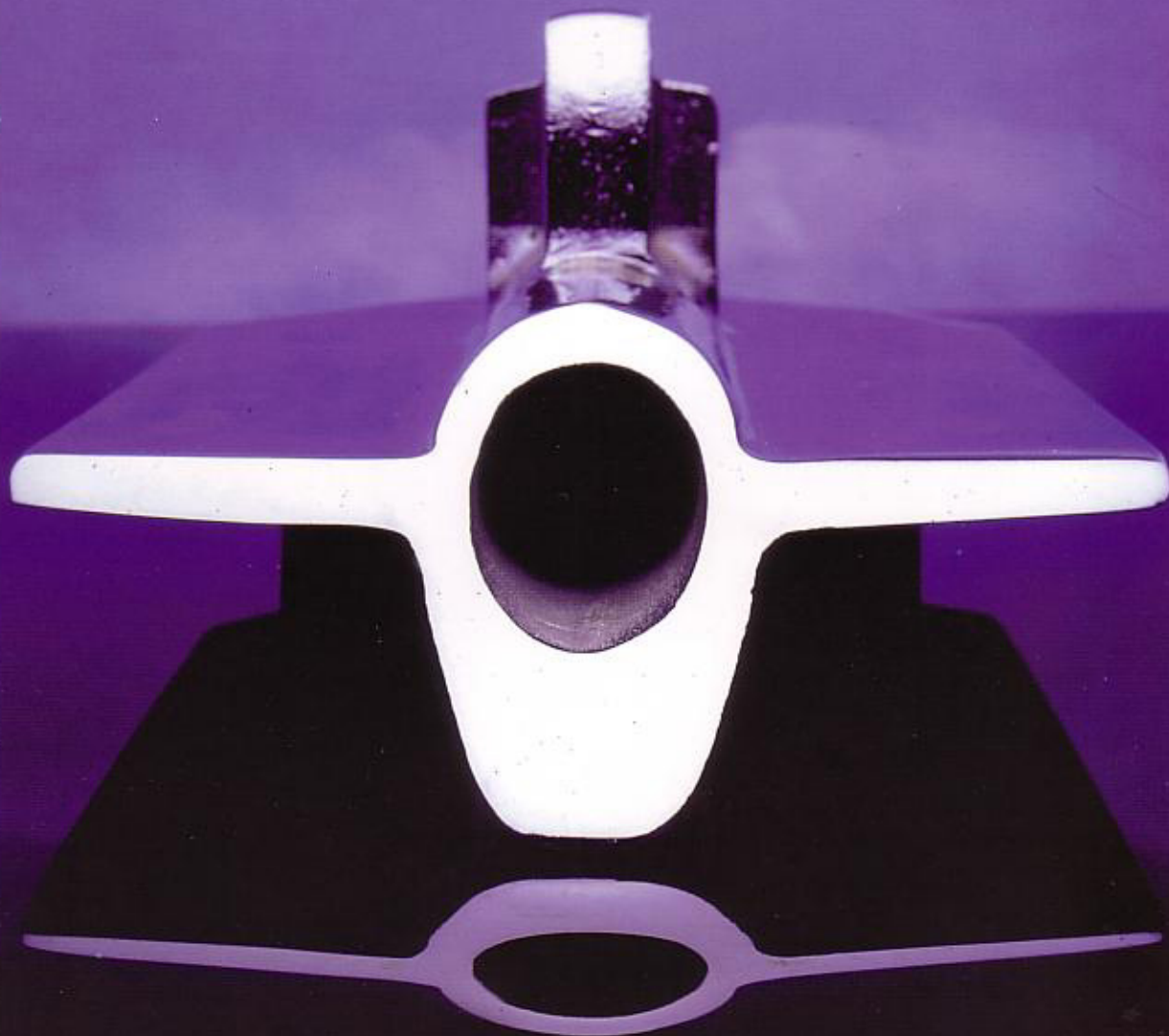



WT Anchor Systems is the exclusive UK supplier of the well proven range of Duckbill mechanical ground anchors as well as a wide variety of grouted anchor systems for temporary and permanent works.

Used extensively for a multitude of structural and groundwork applications, Duckbill anchors provide an efficient and cost-effective means of stabilising stone and masonry structures as well as slopes and embankments consisting of virtually any displaceable substrate.

As part of its on-going programme of improving Duckbill performance, WT Anchor Systems was instrumental

in the design and application of complete stainless steel anchor assemblies to enhance their strength, durability and overall life expectancy.

With the introduction of the Duckbill SR1, proof loads up to 300kN are achievable on a single mechanical anchor in the right ground conditions.

In addition, WT has been responsible for developing the concept of grouted mechanical anchors which further increases their effectiveness in weak substrates.

Part of the WT Group, WT Anchor Systems was formed in 1995 and offers a comprehensive advice, design specification and site testing service. It supplies ground anchors to principal contractors or direct to clients throughout the UK, Ireland and parts of mainland Europe.

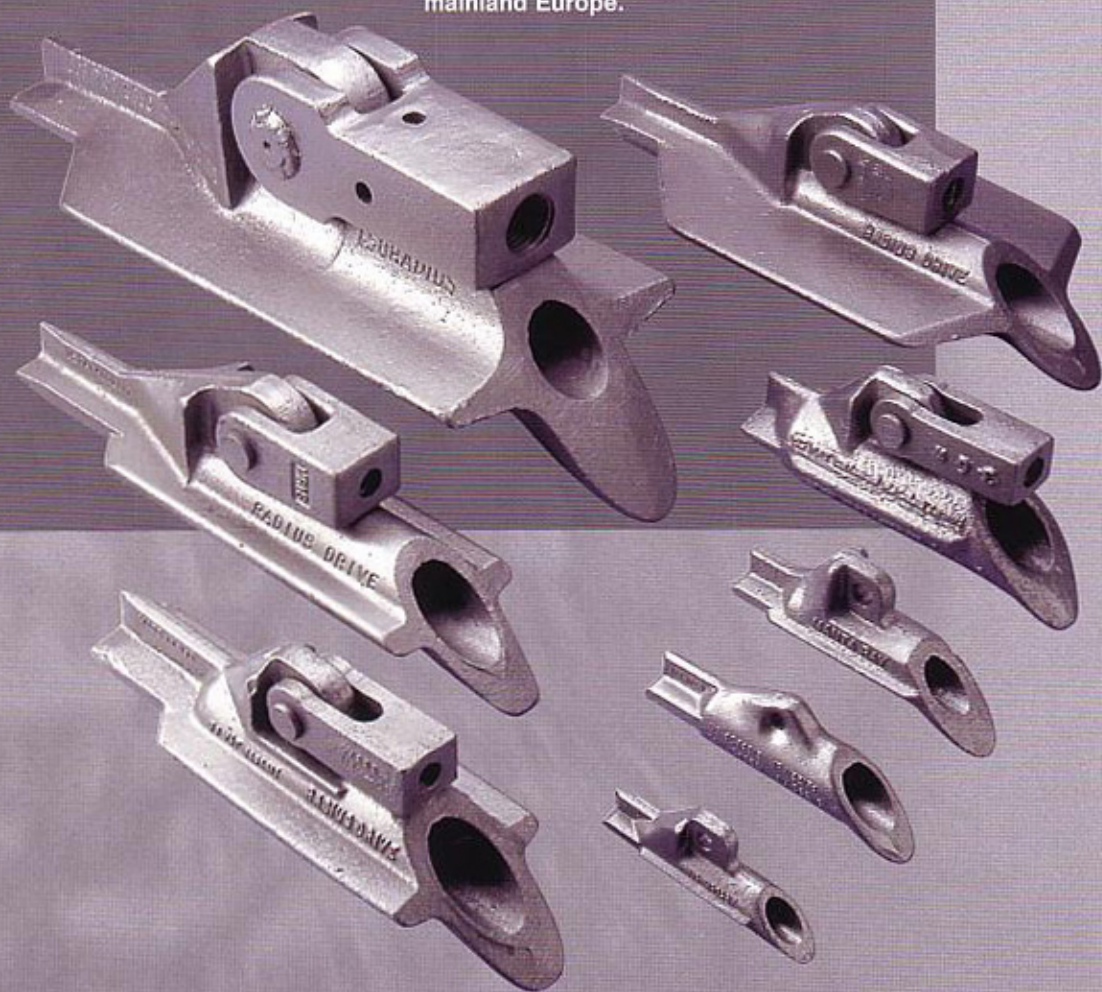

Applications

Reliable

Providing immediate, simple and very effective stabilisation, Duckbill mechanical ground anchors have wide ranging applications for both temporary and permanent works and have proved themselves to be reliable under virtually all displaceable ground conditions.



Cost-effective

With rapid installation, they are both efficient and cost-effective and have been successfully employed around the world for stabilising structures, securing temporary works, erosion control and underwater projects



Versatile

Duckbill anchors can be supplied in anodised aluminium, galvanised cast iron and complete stainless steel assemblies. They are available in a range of sizes and offer a choice of termination plates, including a fully concealed top termination with the Combi-Tec system, making them ideal for historic or listed structures.



Structural Stabilisation Erosion Control Temporary Structures Underwater Fixtures

- ◆ Sheet piles
- ◆ Retaining walls
- ◆ Bridge abutments
- ◆ Lock and canal walls
- ◆ Tunnel linings
- ◆ Gabion baskets
- ◆ Revetment matting



- ◆ Coastal defences
- ◆ Cliff stabilisation
- ◆ Overhead gantries
- ◆ Geotextiles and bio rolls
- ◆ Highway and railway embankments
- ◆ Scaffolding
- ◆ Guyed structures and masts
- ◆ Temporary re-locatable structures
- ◆ Pipelines and buoys
- ◆ Seabed matting
- ◆ Floating docks



- ◆ Tree kits
- ◆ Ski mats
- ◆ Security chains and locks
- ◆ Covered tennis courts

The Range

Load Bearing
& Pattress Plates

Tie Bars and Tendons



Anchor Type	Material	Tie Bars / Tendons	Components
DB68 MATERIAL: Aluminium ULTIMATE LOAD RANGE: 1 – 5 kN		TENDONS: Paracore; Stainless Steel; MS Galvanised	Geotextile Revetment
DB88 MATERIAL: Aluminium ULTIMATE LOAD RANGE: 1 – 10 kN		TENDONS: Paracore; Stainless Steel; MS Galvanised	Geotextile Revetment
MR88 MATERIAL: Cast Iron SG ULTIMATE LOAD RANGE: 5 – 15 kN		TIE BAR: H.Y. Carbon Steel TENDONS: Paracore; Stainless Steel; MS Galvanised	Wedge Grip
MR4 MATERIAL: Cast Iron SG ULTIMATE LOAD RANGE: 10 – 20 kN		TIE BAR: H.Y. Carbon Steel TENDONS: Stainless Steel; MS Galvanised	Washer & Nut Wedge Grip
MR3 MATERIAL: Stainless Steel Cast Iron SG ULTIMATE LOAD RANGE: 15 – 30 kN		TIE BARS: H.Y. Carbon Steel Stainless Steel TENDONS: Stainless Steel MS Galvanised	Washer & Nut Wedge Grip
MR2 MATERIAL: Stainless Steel Cast Iron SG ULTIMATE LOAD RANGE: 30 – 50 kN		TIE BARS: H.Y. Carbon Steel Stainless Steel TENDONS: Stainless Steel MS Galvanised	Washer & Nut Wedge Grip
MR1 MATERIAL: Stainless Steel Cast Iron SG ULTIMATE LOAD RANGE: 50 – 90 kN		TIE BARS: H.Y. Carbon Steel Stainless Steel TENDONS: Stainless Steel MS Galvanised	Washer & Nut Wedge Grip
SR1 MATERIAL: Cast Iron SG ULTIMATE LOAD RANGE: 60 – 300 kN		TIE BARS: H.Y. Carbon Steel	Washer & Nut Wedge Grip

Duckbill Anchor Sizes

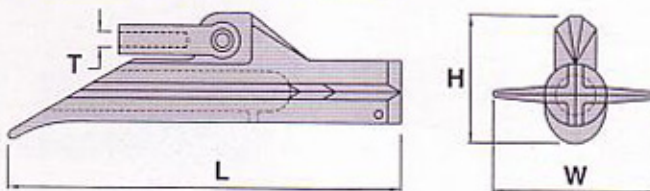

ANCHOR	L	W	H	Sq.mm	T
SR1	533	180	170	74000	30 40
MR1	362.5	175	107.5	46875	16 20
MR2	362.5	87.5	107.5	25625	16 20
MR3	290	87.5	97.5	21250	12 15
MR4	200	62.5	95	10625	10 12
MR88	158	48	65	6250	8 10

Dimensions in millimetres

Other Products

In addition to the Duckbill range WT Anchor Systems also supplies Ischebeck Titan anchors and soil nails, rock bolts and Cintec, Grip-Bar and helical anchors providing loading capacities from 1kN - 2,000kN.

Installation

Machine mounted

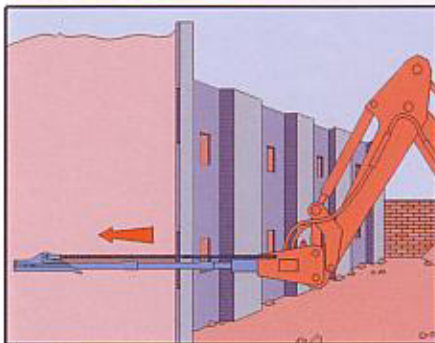

Duckbill anchors are designed to be driven into the ground using hydraulic or pneumatic equipment, with little or no disruption to the structure or surrounding area.

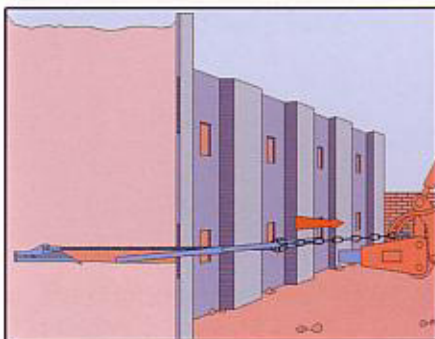

Once the anchor has been driven to the required depth the drive rod is removed.

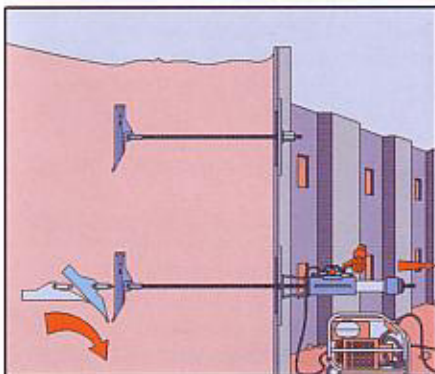

A tensile load is applied to the attached tie bar or tendon. This rotates the anchor into the locked position for maximum load holding capacity. The anchor is then proof tested to the designed loading requirements before the top termination is fitted, as specified by the civil or structural engineer.

Hand held

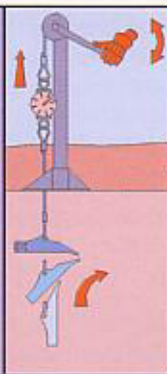
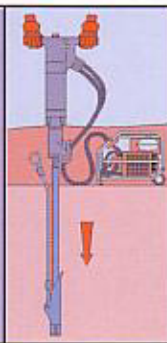

Combi-Tec installation procedure

1. Remove stone or brick or core drill clearance hole



2. Position anchor for installation



3. Drive in anchor to required depth



4. Insert Combi-Tec over Duckbill anchor



5. Inflate sock by injecting cementitious grout and leave to cure



6. Tension anchor to working load and secure to recessed front plate with load nut



7. Crop excess bar, mortar around Combi-Tec



8. Replace cored material and make good



Combi-Tec concealed top termination

Developed by WT Anchor Systems, the Combi-Tec system comprises a stainless steel tube, front plate and polyester sock which is inserted over the installed anchor before pressure filling with grout to produce a mechanical and chemical bond within the structure. This provides a totally concealed top termination for Duckbill ground anchors, making it ideal for historic and listed structures.

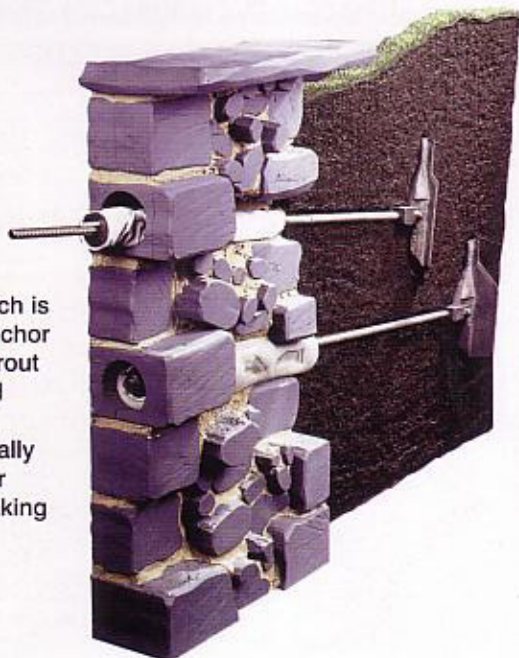

Pipeline Anchoring System

- ◆ for land or underwater applications
- ◆ corrosion resistant components
- ◆ Kevlar webbing connects pairs of anchors to secure pipeline

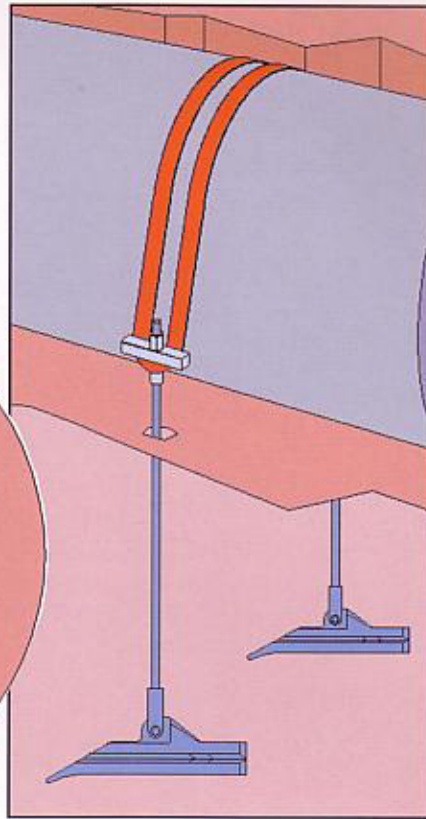
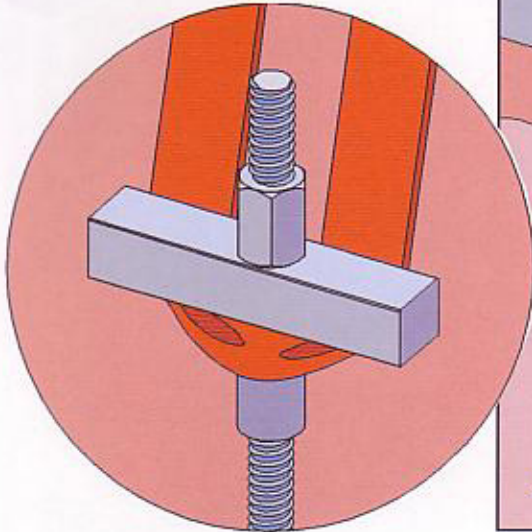

High Yield Bars

- ◆ carbon steel for temporary applications
- ◆ stainless steel for permanent and corrosive situations
- ◆ stainless steel tensile strength in excess of 650N/mm²



- ◆ can be cut on site without damaging thread
- ◆ anchors can be simply extended as required by means of a threaded coupler
- ◆ system can be safely grouted to enhance performance
- ◆ enables anchors to be re-tensioned, if necessary

Comprehensive Service

Advice and specification assistance

Our technical team is available to provide advice on appropriate anchor schemes. To prepare a specification it is essential to establish: load requirements with safety factors; soil characteristics; soil report; bore hole logs if available; installation depth of anchor and setting out; design life of the system; top end termination.

Site testing

The anchor system should always be proof tested on site prior to commencement of the main works to confirm the holding capacity of the anchor in the prevailing substrate

Installation service

For those clients requiring complete supply and installation we can offer a list of approved contractors for most areas.

Equipment hire

For clients involved in a one-off installation or who do not intend to purchase equipment we offer for hire all the necessary tools and equipment to undertake anchor installation.

Tree Anchoring Systems

- ◆ no moving parts
- ◆ no more broken teeth, frayed wires or slipping wheels
- ◆ robust and easy to install
- ◆ anchor points hidden below ground
- ◆ no special tensioning tools needed
- ◆ easily re-tensioned or de-tensioned

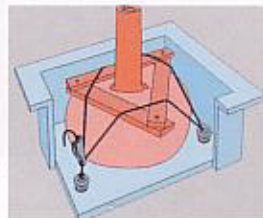
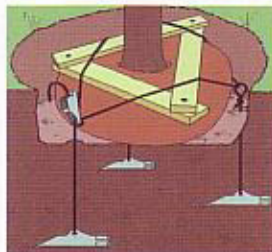

Design & Performance Considerations

Load Range

From 0-300kN subject to ground conditions

Required Life Span/Material Specification

- 1) **Long Term** corrosion resistance for up to and in excess of 120 years using Grade 316 passive stainless steel.
- 2) **Medium Term** up to and in excess of 40 years using cast iron galvanised anchors fitted with stainless steel tendons.
- 3) **Short Term**, i.e. temporary works, using cast iron galvanised anchors with either carbon steel high yield bars or galvanised tendons.
- 4) **Light Weight** anchors are normally supplied in LM 25 aluminium.

N.B. All of the above are subject to prevailing ground conditions and the presence of any aggressive properties such as acids or stray electrical currents. Insulators or insulating membranes should always be used to separate dissimilar metals.

Performance requirements

Working and proof loads are achieved by selection of the appropriate anchor for the ground conditions. All components, including tie bar details, are designed to a safety factor as agreed with the specifier.

Programme considerations

The simplicity of the system and its speed of load application make the Duckbill system a favourite for tight programme situations.

Visual appearance

Top terminations for tie bars and tendons can be varied to suit the situation. These can be fully concealed for visually unobtrusive stabilisation of historic or listed structures. Pattress plates in various sizes, shapes and materials are available to suit specific requirements.

DUCKBILL ULTIMATE HOLDING CAPACITIES IN kNs

COMMON SOIL TYPE	GEOLOGICAL SOIL	Typical Blow Count 'N'	MR-88	MR-4	MR-3	MR-2	MR-1	SR1
Description	Classification							
Very Dense and/or Cemented Sands; Coarse Gravel and Cobbles	Caliche, Nitrate-Bearing Gravel/Rock	60-100+	20	40	50	90	100	300
Dense Fine Sand; Very Hard Silts and Clays	Basal till; Boulder Clay Cliche; Weathered Rock	45-60	20	40	50	90	100	250
Dense Clays, Sands and Gravels, Hard Silts and Clays	Glacial Till; Weathered Shales, Schist Gneiss, Siltstone	35-50	20	40	50	90	100	250
Medium Dense Sandy Gravel; Very Stiff to Hard silts and Clays	Glacial till; Hardpan	25-40	15	30	40	60	90	180
Medium dense Course Sand and Sandy Gravel; Stiff to Very Stiff Silts and Clays	Saprolites Residual Soils	14-25	15	30	40	60	90	180
Loose to Medium Dense Fine to Coarse Sand; Firm to Stiff Clays and Silts	Dense hydraulic Fill; Compacted Fill; Residual Soils	7-14	15	20	30	50	70	150
Loose Fine Sand; Aluminium; Soft-Firm Clays; Varied Clays; Fill	Flood Plain Soils; Lake Clays; Adobe; Gumbo Fill	4-8	4-7	7-11	13-22	22-26	50	100
Peat, Organic Silts; Inundates, Silts Fly Ash	Miscellaneous Fill; swamp Marsh	0-5	0.9-4	1.3-7	3.5-13	9-22	13-37	20-60

N.B. For guidance Purposes Only - True Capacity must be Tested with Load Locker

Tests have conclusively shown that if an anchor is grouted into poor ground, the results achieved are very good. Details are available upon request.

Note: All underground work requires proper safety and location procedures. do not install an anchor until you know what is below the surface. It is imperative in all cases that all anchors are fully load locked before being put into service.

Corrosion susceptibility of metals

LEAST SUSCEPTIBLE

to corrosive attack (more noble)

Platinum
Gold
Silver
Stainless Steel, Type 316 (passive) - Duckbills

Stainless steel, Type 304 (passive)

Titanium and its alloys

Monel

Copper-nickel alloys

Copper

Aluminium bronzes

Gunmetals

Brasses

Tin

Lead

Stainless steel, Type 316 (active)

Stainless steel, Type 304 (active)

Lead/tin solder, 50/50

Stainless steel, Type 410 (active)

Cast iron

Mild steel

Cadmium

Aluminium and its alloys

Zinc and its alloys

Magnesium and its alloys

MOST SUSCEPTIBLE

to corrosive attack (less noble)

DUCKBILL
Ground Anchor Systems